

User Manual

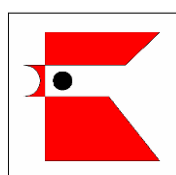

**Rotisseries „Top Line“
RT - Series**



ubert®

1 Contents

1	Contents	3
2	Important References	4
2.1	Fundamental Safety Notes	4
2.2	Warranty and Liabilities	5
2.3	Symbols and Notes	5
2.4	Copyright	5
2.5	Special safety references	6
3	Introduction	8
3.1	Technical details	8
4	Installation and starting the operation	13
4.1	Unwrapping	13
4.2	Installation	13
4.3	Electrical connection	13
4.4	Preparation of Operation / Starting up	14
5	Operation	15
5.1	Operation of rotisseries equipped with manual controls	15
5.2	Operation of rotisseries equipped with computer control	17
5.3	Explanation of the computer control (overview)	18
5.4	Operation, handling and cleaning of WRT probes (optinal accessory)	22
5.5	Rotisserie assembly for operation	25
5.6	Product mounting and loading	27
6	Maintenance	28
6.1	Cleaning and care	28
6.2	Trouble shooting	29
6.3	Wiring Diagrams	31
6.4	Spare Parts	34
6.5	Declaration of Conformity	41

2 Important References

2.1 Fundamental Safety Notes

2.1.1 Consider notes in the operating manual

Precondition for the safe and trouble free use of this unit is the knowledge of the fundamental safety notes and safety regulations.

The operating instruction contains the most important references to operate the unit safely.

These operating instructions, particularly the safety references, are to be considered by all persons, who work on the unit.

Furthermore the rules and regulations to avoid accidents are to be considered.

2.1.2 Obligation of the operator

The operator is obliged to only let persons work with the unit who:

- Are familiar with the fundamental regulations of work safety and accident avoiding and who have been instructed how to operate the unit.
- Read and understood the chapter about safety and warning notes and have confirmed this by signature.

The safe conscious operation of the staff has to be examined regularly.

2.1.3 Obligation of the staff

All individuals who are authorized to work with the unit are obliged to:

- Pay attention to the fundamental regulations of work safety and accident avoiding,
- Read the chapter on work safety and warning notes in this manual and to confirm through their signature that they have understood these, before actually operating the unit.

2.1.4 Possible risks

The TopLine Rotisseries are built state of the art and in acknowledgement of all safety related rules. Nevertheless is it possible that danger for body and lifes of the user and/or third and/or impairments at the unit or at other real values merge. The unit is to be used only:

- For the due use.
- In safety related flawless condition.

Disturbances which can hurt the safety are to be eliminated immediately.

2.1.5 Due use

The TopLine Rotisseries are built exclusively for the preparation of food only. Any other use of the unit is only allowed after consulting UBERT GASTROTECHNIK GMBH. Damages which result out of wrong use UBERT GASTROTECHNIK GMBH cannot be held responsible. Part of the due use is also:

- The consideration of all references of the operating manual and
- The observance of necessary maintenance and service.
- We recommend a semi-annually maintenance interval.

2.2 Warranty and Liabilities

Fundamentally our "General terms of sale and delivery" are valid. These are known to the operator at the latest since signing of the contract. Claims to warranty and liability at persons- and property damages are impossible, if they are to be led back to one or several of the following causes:

- Non due use of the unit.
- Improper assembling, starting up, operating and servicing of the unit.
- Operating the unit with defective safety devices or safety devices which have not been installed properly and are in no working condition.
- Disobeyment of the references in the operating manual concerning transportation storage, installation, start-up, operation, maintenance and assembling of the unit.
- Unauthorized mechanical or electrical changes of the unit.
- Unsufficient maintenance of wear and tear parts.
- Unauthorized repair.
- Force of nature and act of god.

2.3 Symbols and Notes

In the operating manual the following symbols and signs are used:



This symbol means a possibly or directly threatening danger for the life and the health of persons and/or a possibly dangerous situation.
Ignoring of these references may result in consequences for your health and/or can lead to property damages!



This symbol points to important references for the proper use of the unit.
Not paying attention to these references can lead to disturbances of the unit or of the environment!



This symbol points to operation tips and especially useful information.
Help to use all functions at your unit optimally

2.4 Copyright

The copyright on this operating manual remains with the company UBERT GASTROTECHNIK GMBH. This operating manual is intended only for the operator and his staff. It contains instructions and references which neither completely nor partially is:

- To be duplicated
- To be circulated or
- To be otherwise made available to third parties.

Offences may violate applicable laws.



2.5 Special safety references

2.5.1 Safety devices

- Before operating the unit all protective devices as well as all removable parts must be installed correctly and be fully workable.
- Protective devices may only be removed:
 - after stand still and
 - Prevention of unintentional restart.
- If partial components are delivered, an authorized staff member or service technician has to execute assembly according to installation guidelines.

2.5.2 Informal safety steps

- The operating manual is to be kept constantly accessible in the operating area.
- In addition to the operating manual all generally acknowledged and all local regulations for accident avoiding and environmental protection have to be applied with.
- All safety- danger labels at the unit are to be kept in readable condition.

2.5.3 Education of the staff

- Only trained and instructed staff is allowed to operate the unit.
- The responsibilities of the staff are to be determined clearly for installing, start-up, operation, assembling, and servicing of the unit.
- During instructing the staff may only work at the unit under supervision of an experienced person.

2.5.4 Unit-control

- Only instructed staff is allowed to operate the controls.

2.5.5 Safety during regular operation

- The unit is only to operate if all protective devices are fully workable.
- At least once per shift the unit is to be examined with regard to visible damages and functional ability of the safety devices.

2.5.6 Dangers caused by electrical energy

- Any work on the electrical supply is to be executed only by a specialist.
- Likewise the electrical connection of this unit to the power supply must be executed by an examined electrician; the connection must follow the rules of the local determinations.
- The electric installation is to be examined regularly. Loose connections and brased cables are to be eliminated immediately.
- If works at any life-parts are necessary, a second person who switches off the main switch if necessary is to consult.

2.5.7 Special danger-spots

- All removable parts like spit, disc or fan cover for instance, are only to be removed if the rotisserie is switched off and all surfaces, inner walls and parts are cold!
- Caution while removing grilled food! All parts may be hot and may cause severe burnings to your skin.
- Do not reach into the rotisserie while the appliance is hot and operating. Keep the doors closed at any time!

2.5.8 Service and maintenance, trouble shooting

- Prescribed adjustment, service and inspection work is to be accomplished timely by the manager or if necessary by an authorized service technician.
- The operating staff is to be informed before the beginning of the maintenance and service work.
- The unit is to be disconnected from the mains before maintaining, inspecting and repairing is done; the main switch is to be supervised against unintended reclosing.
- Check all screw connections for tight fitting.
- After finishing maintenance check all safety devices for proper functionality.

2.5.9 Structural changes to the unit

- Do not perform any changes, extensions or conversions to the unit without the manufacturer's permission, especially welding work at supporting parts.
- For all conversions a written permission of the company UBERT GASTROTECHNIK GMBH is necessary.
- Change all parts of the unit that are in improper condition.
- Use only original spare parts.

2.5.10 Cleaning of the unit and disposal of the waste

Used substances and materials are to be handled and disposed appropriately, especially lubricants. Detergents have to follow the rules of food-hygiene.

3 Introduction

3.1 Technical details

3.1.1 Dimensions [mm]

RT403S / RT 403 – RT 406:

RT403S CC / RT403 CC – RT406 CC:

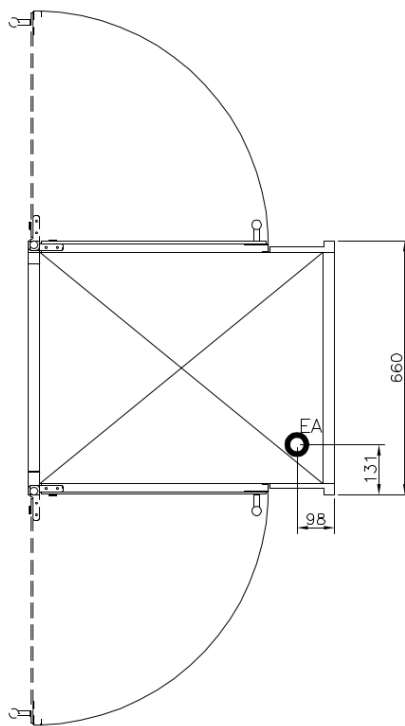
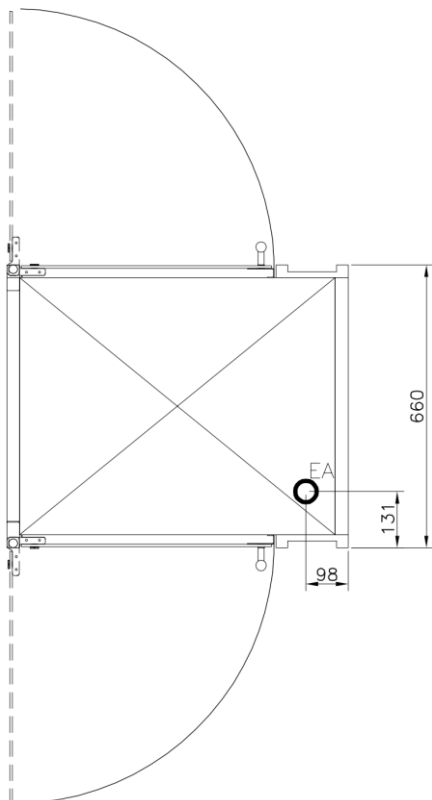
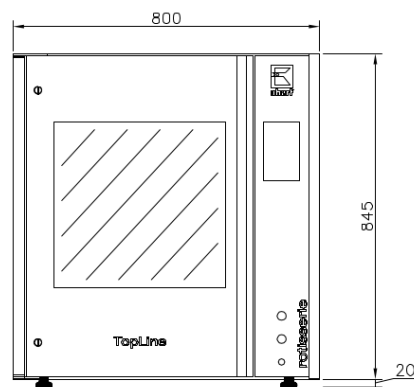
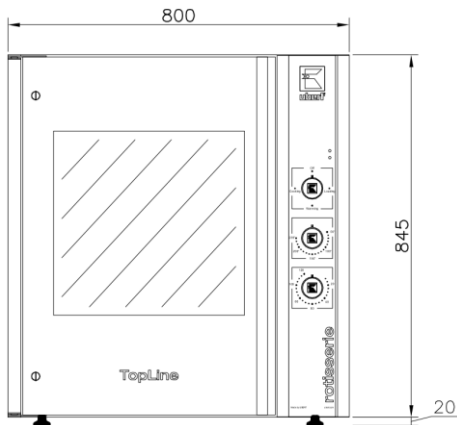

RT407 - RT408:

RT407 CC – RT408 CC:

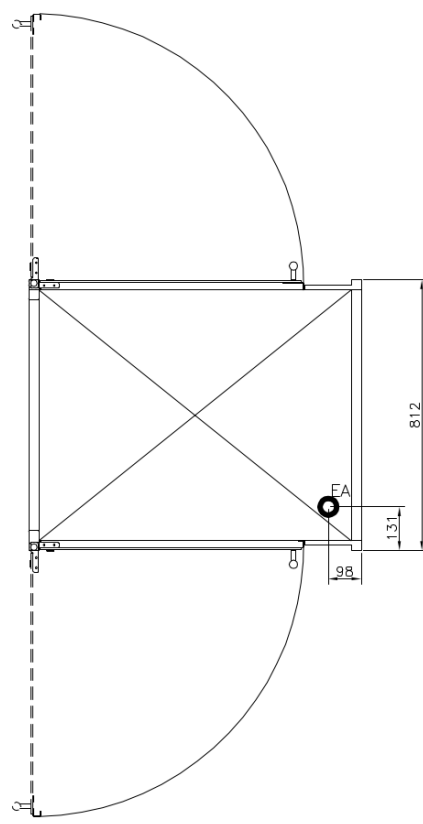
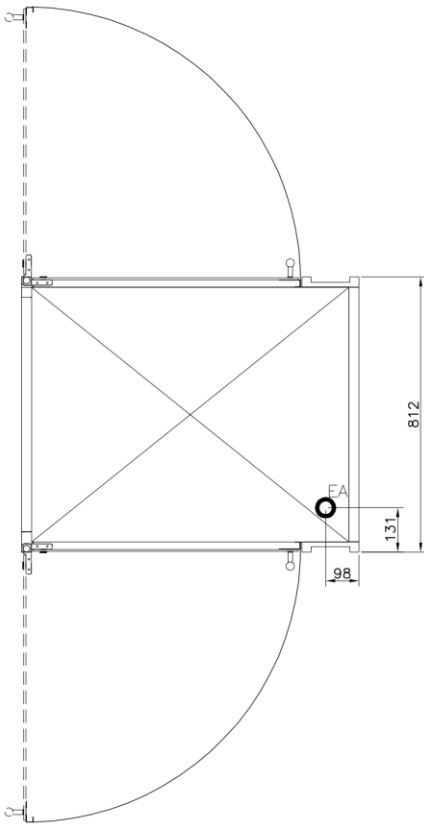
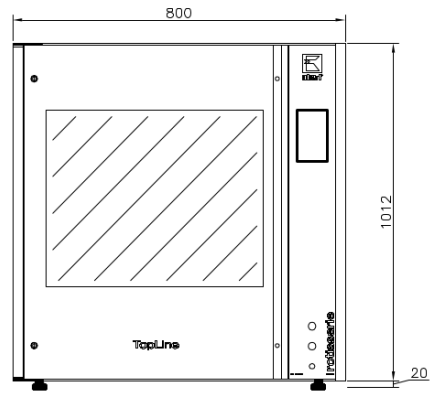
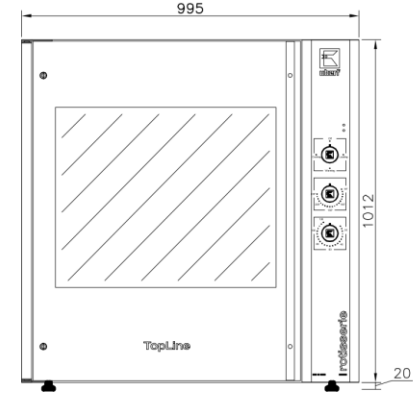

RT412:

RT412 CC:

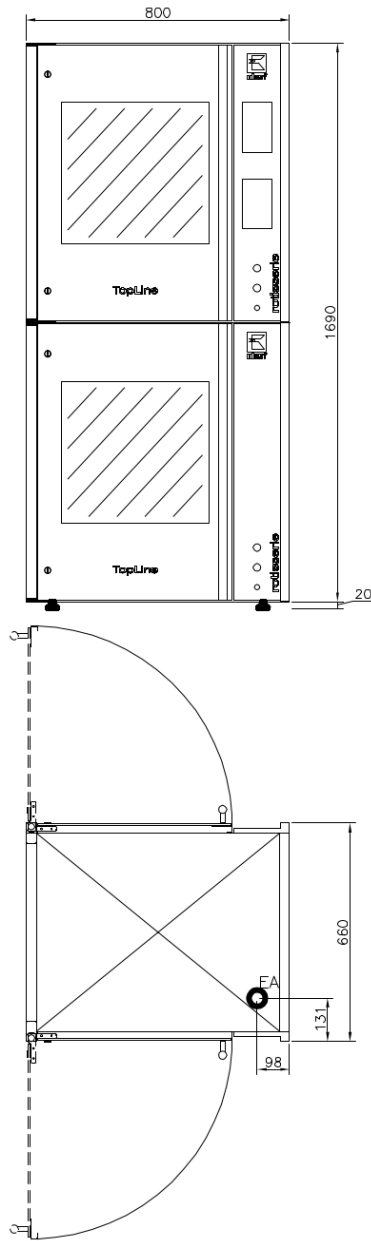
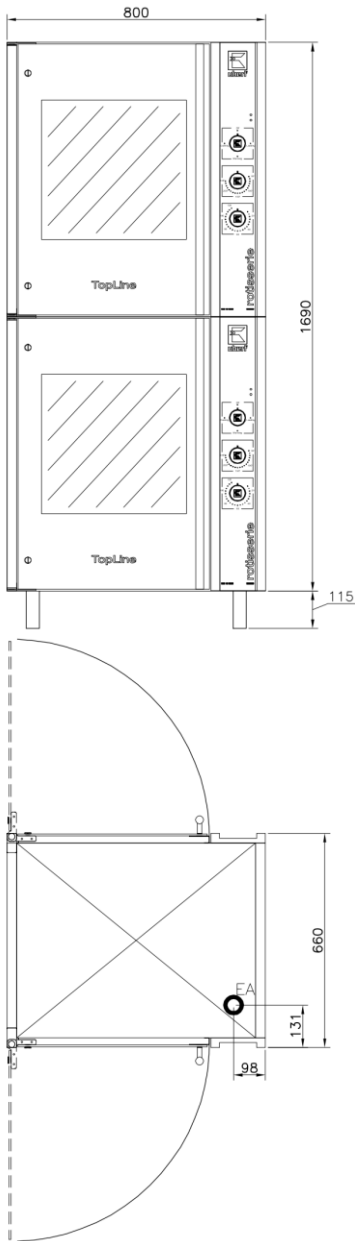

RT 416:

RT416 CC:

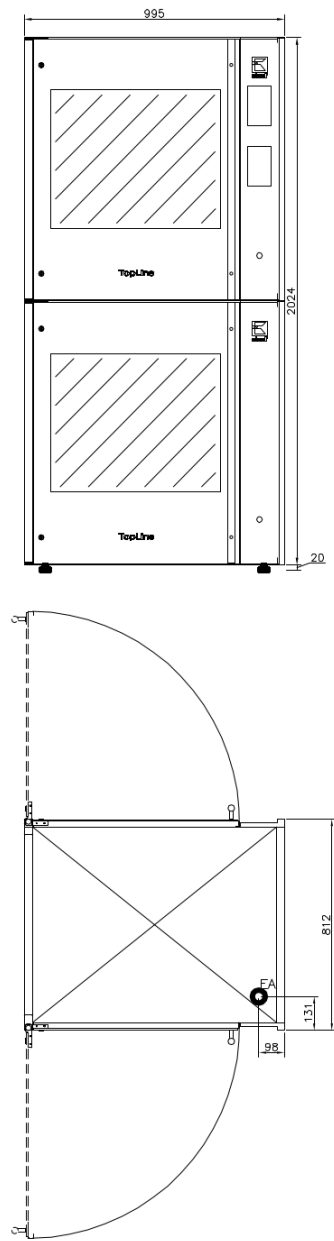
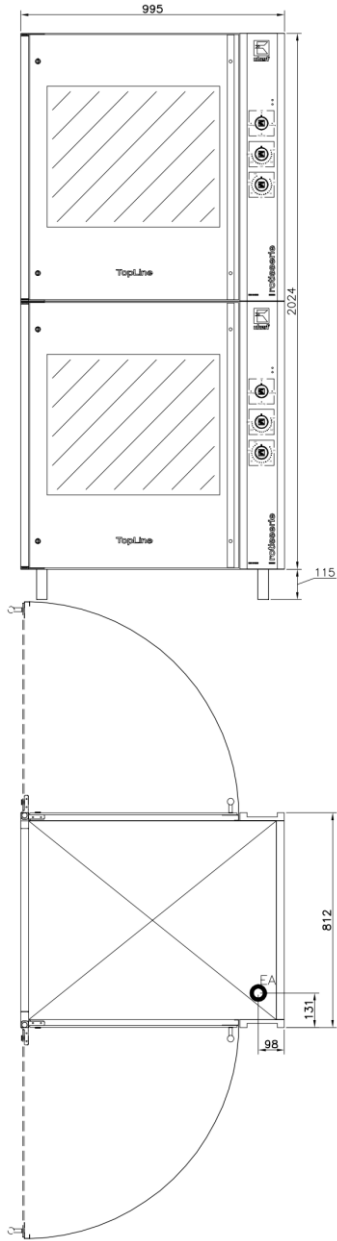

3.1.2 Weight

<u>Type</u>	<u>weight (in kg)</u>
RT403S [CC]	ca. 92
RT 403- RT 406 [CC]	ca. 92
RT 408 [CC]	ca. 169
RT 412 [CC]	ca. 184
RT 416 [CC]	ca. 338

3.1.3 Electrical details

<u>Type</u>	<u>electrical connection [EA]</u>	<u>power</u>
RT 403S [CC]	230V, 1/N, 50Hz	3.5kW
RT 403 [CC]	400V, 3/N, 50Hz	5.0kW
RT 404 [CC]	400V, 3/N, 50Hz	5.5kW
RT 405 / RT 406 [CC]	400V, 3/N, 50Hz	6.0kW
RT 408 [CC]	400V, 3/N, 50Hz	11.1kW
RT 412 [CC]	400V, 3/N, 50Hz	12.0kW
RT 416 [CC]	400V, 3/N, 50Hz	22.2kW

3.1.4 Noise emission

<u>Type</u>	<u>noise emission</u>
all types	< 70 dB (A)

4 Installation and starting the operation

In general all Rotisseries „Top Line“ will be packed for safe transport after the final control in order to reach you properly. Nevertheless we ask you to have a look at the machine on arrival to check on any possible transport damages.



Note! Visible damages have to be reported immediately!

4.1 Unwrapping

- Open the carton and take out the wrapping material carefully.
- Take care that the delivery is complete (see attached freight documents).

4.2 Installation

Place the Rotisserie „Top Line“ at the desired location. Make sure, that it is good visible for your customer to ensure good food presentation and successful sales.



Take care of the following points:

- The TopLine Rotisserie (with or without stand) has to be placed on a horizontal level. Use a spirit level if necessary.
- Note that all ventilating slots have a free space from a wall or similar of at least 10cm (app. 4 inch).
- Location underneath a ventilation system is usefull and recommended.
- There has to be enough free space to load, unload, clean and maintain the unit.
- The machine has to be placed in a way that the complete area around it can be cleaned easily.

4.3 Electrical connection

Note! In general, only service technicians of the company: UBERT GASTRO-TECHNIK GMBH or service technicians of your responsible service partner are allowed to perform el. connection and other service! All national and local rules and regulations concerning electricity, fireprotection and similar have to be considered. During any servicing, take care that the unit is disconnected from the mains! Not paying attention may result in injury!



Please learn the electrical and technical data of your unit from the name plate.

- Check whether your local electrical power supply is in accordance with the values on the name plate.
- The power supply needs to be manufactured from heat resistant, flexible cable. It is to be routed to prevent any contact to hot parts.
- The unit is to be connected to the power supply either by means of an appropriate plug or if connected permanently, a switch (interrupting all poles) is to be provided. In case of an emergency the power supply must be interruptable immediately.
- For further information please see the wiring diagram (attached).

Note!

After finishing any installation work, maintenance or repairs check whether the ground wires are connected properly to the casing.



4.4 Preparation of Operation / Starting up

Before you can operate the TopLine Rotisserie you have to clean the unit and all removable parts (e. g. spits, discs etc) carefully with a grease solvent detergent. Afterwards you have to dry all surfaces.

Note! Do not use flammable cleaners. Do not use high pressure-, water pressure- or steam jet- cleaning machines. You will have further information about this in the section 'cleaning and maintenance'.



After cleaning the TopLine Rotisserie properly the smell will be minimal when using it the first time.

5 Operation

Following you will find explanation and location of all components and their function for the use of the TopLine Rotisserie.

5.1 Operation of rotisseries equipped with manual controls

5.1.1 Operating panel

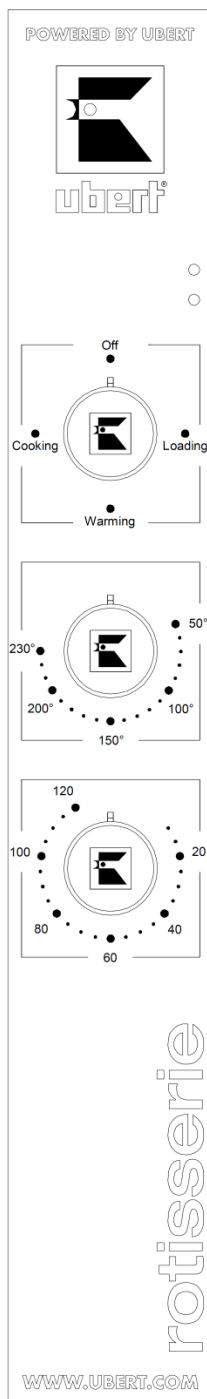

- Yellow Pilot Light: Indicates heating elements are running.
- Green Pilot Light: Indicates rotisserie is switched on.
- Function Switch:
To load the rotisserie, switch the Function Switch to **LOADING**. The ventilation will start immediately. You may now load the first spit. Switch to **WARMING** to rotate the disks to the next spit position. Go ahead loading your rotisserie by frequently changing between the two different switch positions **LOADING** and **WARMING** until the disc is fully loaded. Now switch to **COOKING** in order to start the grill operation.
- Temperature control:
The thermostat allows you to preset the desired grill temperature. You may choose temperatures up to 250°C. The temperature is controlled by a thermostatic control.
- Timer (1):
You may adjust the desired grilling time with the timer. It may last up to 120 minutes. Once the time has counted down, an acoustic alarm will ring. The heating elements will switch off, light and spit rotation will continue.

Timer (2):

Works the same way as Timer (1), except for an additional switch position (∞) that allows continuous operation without a time limitation.

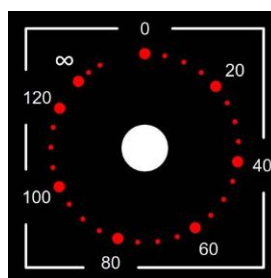

5.1.2 Manual Operation

- To preheat, turn function switch to COOKING, adjust the desired temperature and set the timer to 20 minutes. Wait for the rotisserie to heat up.
- To load the products, turn function switch to COOKING.
 - a. Open the door.
 - b. Turn the function switch to WARMING to rotate the disks to the desired position and then turn the function switch to LOADING to stop the rotation.
 - c. Load the spits using pliers or spit handles as shown below
 - d. Repeat steps b and c until all spits have been loaded. Close the door.
- Set the desired temperature using the temperature control.
- Set the desired time using the timer
- The rotisserie will now cook until the time has run out and an accoustic signal will ring.
- The products can be unloaded the same way as they were loaded.

- Turn the function switch to OFF to turn the rotisserie completely off.

5.2 Operation of rotisseries equipped with computer control



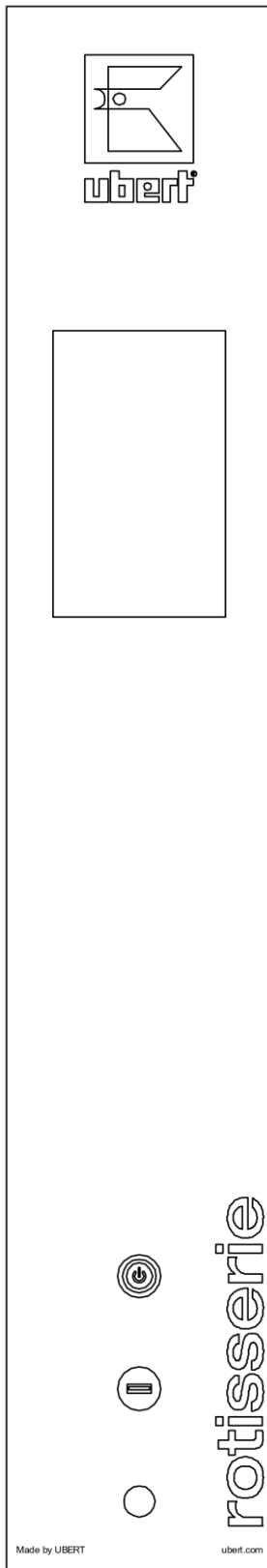

5.2.1 Operating panel



- **Computer control**
The controller is used to control the complete cooking process automatically, including cooking time period, cooking temperature and cooking end time.
- **Main switch to switch the rotisserie ON and OFF:**
- **USB-Port to connect a USB Data-Stick allowing:**
 - to create backup and restore of cooking programs
 - to update the firmware of the controller
- **Outlet of wire-connected core temperature probe (optional accessory)**

5.3 Explanation of the computer control (overview)

The computer control offers 5 keys on the home menu that represent the main sections:

	<p>In the cooking section, you can:</p> <ul style="list-style-type: none"> - select from and run various predefined cooking programs - select and run a boost program (if enabled) - use the manual mode (if enabled) to cook the products without predefined settings
	<p>In the programming section you can preset cooking programs.</p> <p>You can use settings from the library or set all parameters from scratch.</p> <p>Cooking programs can be:</p> <ul style="list-style-type: none"> - batch-programs (to cook a full batch of products at a time) - vario-programs (to cook similar products at the same oven climate but with individual cooking times or target core temperatures)
	<p>In the user parameter section you can adjust various personal preferences such as language, access code (factory default is 1965), date&time, enable/disable a wired core temp.probe, enable the manual mode or a boost program or disable both, pair/unpair WRT probes (wireless temperature probes), select the temperature scale (°C/°F), set the max. amount of batch grilling phases, set an emptying prompt for the grease collector drawer, select which warming lamp to use, enable/disable automatic program start and end, set frequency and volume of the buzzer, backup cooking programs to or restore them from a USB stick.</p>
	<p>In the help section, you get detailed information on all keys and functions.</p> <p>The help key can be pressed at any time to get specific information on the actual screen.</p> <p>Use the up and down key to scroll through the help pages. Press the back key to return back to the screen you came from.</p>
	<p>In the service section, you can</p> <ul style="list-style-type: none"> - read out the software version of the controller - confirm error messages after solving their cause. <p>Besides that, there is also a section included, that is reserved for service technicians.</p>

5.3.1 Cooking section

To operate the rotisserie via the computer control, press the ON/OFF switch. The controller will start, showing the manufacturer logo and will boot into the home screen.

5.3.1.1 Cooking section / manual operation mode:

Once the controller is ready, press the cooking section key and then the manual key to start the manual operation mode.

Press the TEMPERATURE key, and use the UP- und DOWN-key to change the set temperature
Use the CONFIRM key to confirm the temperature setting.

Press the TIME key, and use the UP- und DOWN-key to change the set time
Use the CONFIRM key to confirm the time setting.

Press the CONFIRM key again to start the cooking process.

Follow the instructions on screen to preheat, load, unload and so on. An acoustic alarm and the ready message on screen indicate the end of the cooking process. Use the CONFIRM key again, to quit the alarm. (If automatic program start and/or end is activated in the user parameter section, opening the door will quit the alarm automatically).

5.3.1.2 Cooking section / programmed operation mode

Once the controller is ready, press the cooking section key. Use the UP- and DOWN-key to scroll through the list of programs. Start the desired program by pressing the corresponding key.
Follow the instructions on screen to preheat, load, unload etc. An acoustic alarm and the ready message on screen indicate the end of the cooking process. Use the START key again, to quit the alarm. (If automatic program start and/or end is activated in the user parameter section, opening the door will quit the alarm automatically).

5.3.1.3 Cooking section / boost

The "Boost" program key is always at the bottom of the list. This program is intended to be used in case of an insufficient core temperature at the end of a cooking cycle.
Follow the instructions on screen. An acoustic alarm and the ready message on screen indicate the end of the boost process. Use the START key again, to quit the alarm. (If automatic program start and/or end is activated in the user parameter section, opening the door will quit the alarm automatically). Re-check core temperature.

5.3.2 Programming section

Once the controller is ready, press the programming section key

Enter the access code (factory default is 1965) and confirm

You can choose between:

New to create a new cooking program

Change to change an existing cooking program

Copy (to copy an existing cooking program

Move to move an existing cooking program to a different location in the list

Delete (to delete an existing cooking program from the list)

5.3.2.1 **New**

Select the position of the new cooking program in the list

Select a program from the library or create your own (Batch- or Vario Program)

+ **Library** programs can be selected to the desired program position. They can be changed later on.

+ **Charge** (or Batch) programs are preset by the following steps:

- Select an Icon

- Enter a Name

- Set a preheat temperature (0=no preheat)

and for up to 8 cooking steps set an individual:

- Temperature

- Time or Core Temperature (requires WRT probe)

If a time $\neq 0$ is selected core temperature will not be available and vice versa.

If non of the them is set, the step will be skipped

and for a subsequent holding step:

- Temperature

- Time or Core Temperature (requires WRT probe)

If non of the them is set, there will be no holding step

+ **Vario** programs are preset by the following steps:

- Select an Icon

- Enter a Name

- Set a temperature and for up to 8 sub programs set an individual:

- Time or Core Temperature (requires WRT probe)

If a time $\neq 0$ is selected core temperature will not be available and vice versa.

5.3.2.2 **Change**

Works the same way as New except for the fact, that the given data can be changed or further steps can be added.

5.3.2.3 **Copy**

Select the source program that you want to copy from the list.

Select the position in the list, to which you want to copy the program to.

5.3.2.4 **Move**

Select the source program that you want to move in the list.

Select the position in the list, to which you want to move the program to.

5.3.2.5 **Delete**

Select the program that you want to delete from the list.

5.3.3 User parameter section

In the user parameter section you can adjust various personal preferences like:

- Select the language.
- Enter a new access code (factory default is 1965).
- Adjust date and time of the real time clock.
- Enable or disable a wire connected core temp.probe.
- Enable the manual mode or allow a boost program to be used or disable both.
- Pair and unpair WRT probes (wireless core temperature probes).
- Select the temperature scale (°C/°F).
- Set the maximum amount of charge grilling phases, cooking steps of batch cooking programs (1-9)
- Set an emptying prompt for the grease collector drawer in cooking hour steps (0=no prompt).
- Select which warming lamp to use (front, rare, both or none).
- Enable or disable automatic program start and automatic program end (to skip the need to confirm)
- Set the frequency (low to high) and the volume (low to high, 0=off) of the buzzer.
- Create a backup of your cooking programs to a USB stick or restore them from a USB stick.

5.3.4 Help section

In the help section, a general help on how to navigate the controller, is provided. Besides that, you can press the HELP-key (?) at any time to get specific information on the actual screen.

Use the UP-key (^) and DOWN-key (v) to scroll through the help pages. Press the BACK-key (<) to return back to the screen you came from.

5.3.5 Service section

In the service section, you can read out the software version of the controller and you can confirm error messages after solving their cause.

Besides that, there is also a section included, that is reserved for service technicians.

5.4 Operation, handling and cleaning of WRT probes (optimal accessory)

Activate the probe charger

To activate the probe charger (cradle), open the magnetic rear cover and remove the protective shield from the charger battery.

To verify the status of the charger battery, press the push button. If the LED lights up green, the charger battery is ok. If not, replace the charger battery (AAA size).

Description of WRT probe

The WRT probe is made is stainless steel. It measures the core temperature at the pointed tip.

Note the safety notch!

The thicker, black coloured end is the ceramic handle.

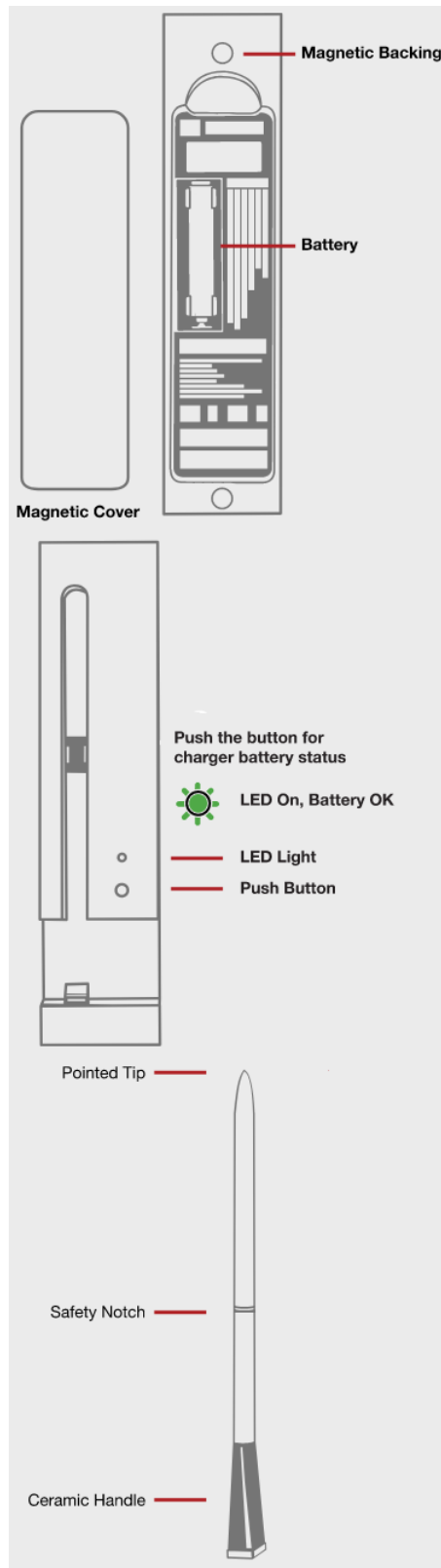

Loading the WRT probe

To load the built-in, re-chargeable battery of the WRT probe, place the probe in the cradle by inserting the tip of the probe first and then the black handle.

Once fully loaded, the re-chargeable battery lasts at least 24 hours.

Allow a new probe to load fully, by keeping it in the charger for 8 hours.

Later, reloading the probe takes only 2-3 hours.

We recommend to store the probe in the charger while it is not in use.

Proper probe placement

Insert your WRT probe in the centre of the thickest section of the meat.

Make sure the temperature critical section of the WRT probe, from the pointed tip to the safety notch, (shown below in grey) is completely inside the meat.



Allow the ceramic handle to stay outside the meat.



Chicken placement



Meat placement



Fish placement

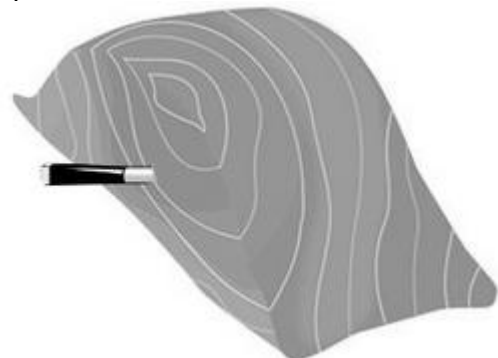

Identification of probes

To identify each probe when operating more than one probe with your rotisserie, probe clips are available. Place the clips onto the probe, adjacent to the ceramic handle.



Cleaning and maintenance of the WRT probe

Make sure to clean the WRT probes after every use. This will ensure hygienic operation and debris-free charging contacts.

The WRT probe is water resistant so you can wash it with water. Use a sponge and mild soap to clean the probe.

If necessary, scrub the metal square above the ceramic handle to ensure proper re-loading of the internal battery.

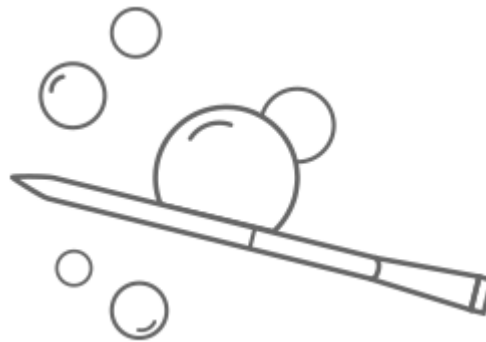

Do not submerge in water for a long period of time!

Do not clean the probe in a dishwasher!

Ensure to **clean and dry** the WRT probe **before** placing it in the charger!

We recommend to store the probe in the charger while it is not in use.

Overnight charging of the probe is recommended to ensure full loading and maximum capacity during worktime.

5.5 Rotisserie assembly for operation

5.5.1 Drip pan and drip plates assembly

Slide the drip pan into the bottom section of the rotisserie.

Assemble the drip plates by placing them on the pins located at the side walls of the oven chamber and the front- respectively the rear panel.

5.5.2 Shaft assembly

- Install Shaft into drive hub. See picture below.

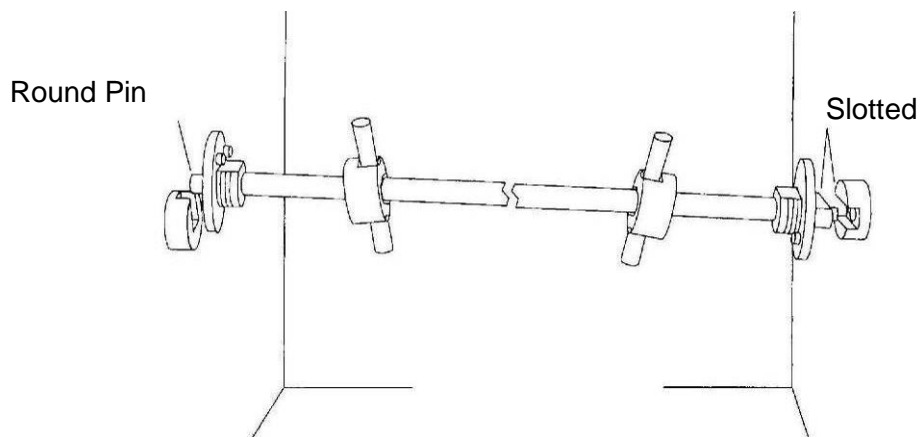

5.5.1 Disk assembly

- Install the disks onto shaft.

Note! The configuration of holes in the disks are different. The disk with two holes near the center is assembled on the left hand side (opposite to motor side) and disk with one hole near center is assembled on the right hand side (motor side).

- Tighten the nuts against the disks.

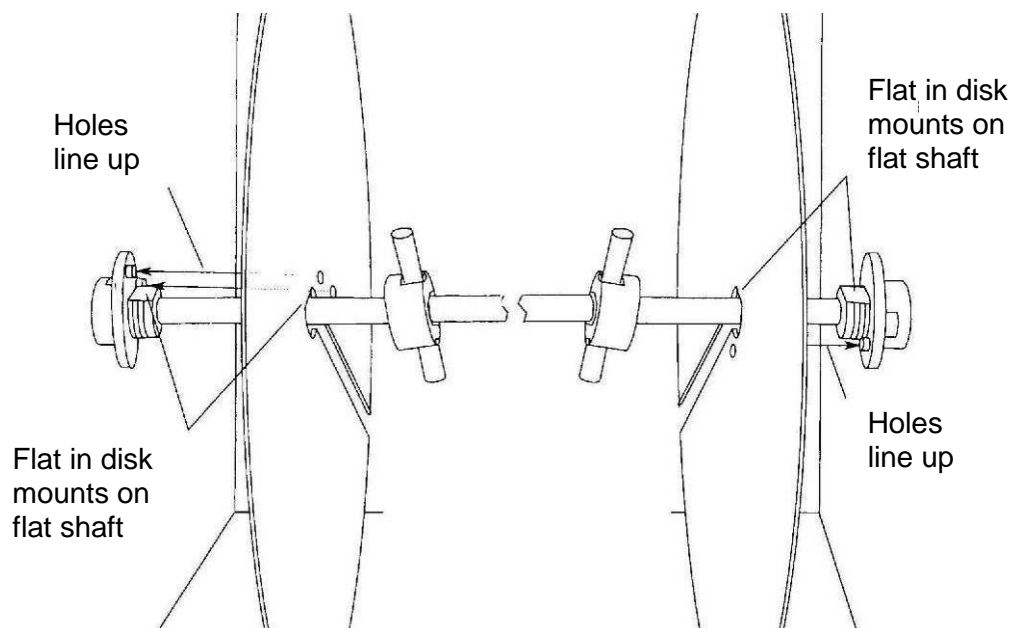

5.5.2 Spit assembly into rotisserie

5.5.2.1 Angle Spit

- For mounting chickens horizontally and without piercing chicken.
- Mount spit into holes as shown below. Be sure recessed rings on end of shafts drop into hole in disk.

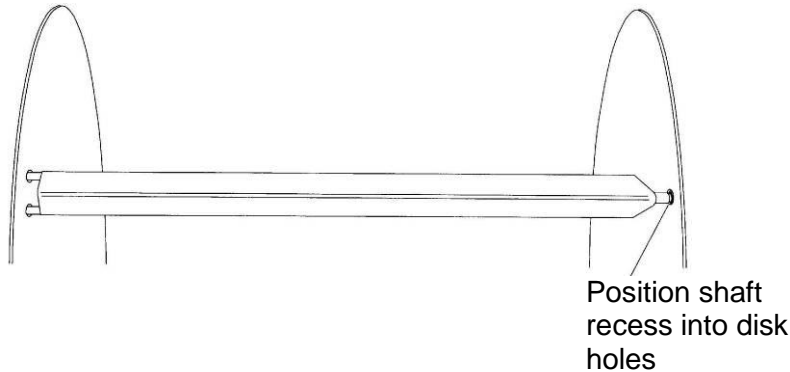

5.5.2.2 Double Spits

- The pointed end of the spits can be assembled into either right or left disk.
- If you are right handed it may be easier to install the pointed end of the spit into the disk on the left as your stronger right hand will be holding the weight of the product while your left hand positions the spit into the disk. If you are left handed the opposite may be true.
- The spits must be positioned with the bend in the supports bracket toward the center as shown below. Position the recesses in the shafts so they drop into the holes in the disk. This will keep the spit from sliding.

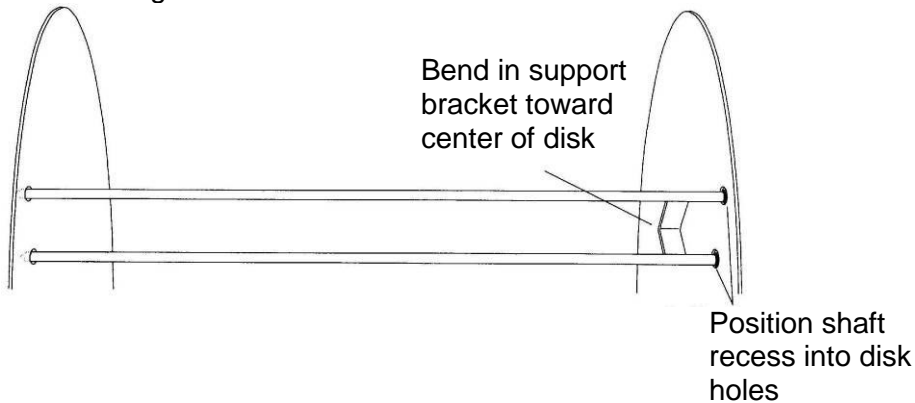

5.5.2.3 Rack and Basket

- Position racks or baskets into holes as shown below. Be sure recessed rings on end of shafts drop into hole in disk as shown below.

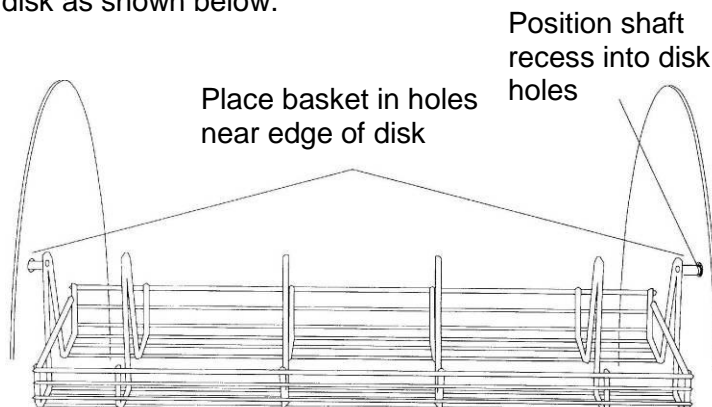

5.6 Product mounting and loading

5.6.1 Angle spits for placing the chickens horizontally

- Insert the spit through the holes in both ends of the chicken while holding the spit angle down and the chicken breast up. See picture below.
- Tie the chicken legs to prevent flopping while grilling. Chickens can be mounted horizontally on Model RT 405 or RT 407 Angle Spits.
- When all chickens are loaded onto the spits use 2 pairs of channel lock pliers to grasp the angle spit as shown in the picture below. The angle spits can then be loaded onto the rotisserie disks using the pliers. Directions for operating the rotisseries and using the loading switch are on the following pages.

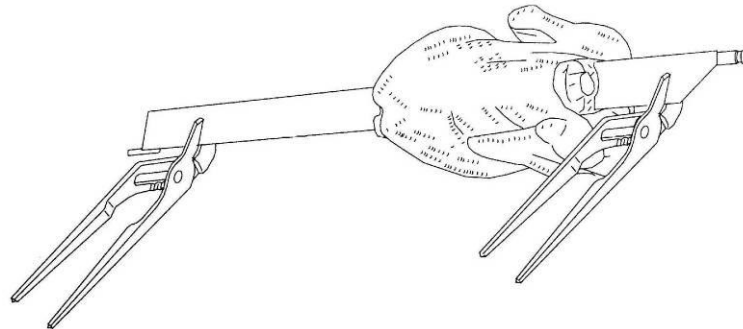

5.6.2 Double spits for placing the chickens vertically

- Lock chicken wings down by tucking under the legs
- When piercing the chicken hold the spit with the support angle down and the chicken breast up.
- Lock the wings down by tucking under the legs and then pierce just below wing with spit and pierce leg just under the bone as shown in the picture below. The spits can then be loaded onto the rotisserie disks using the pliers. Directions for operating the rotisseries and using the loading switch are on the following pages.

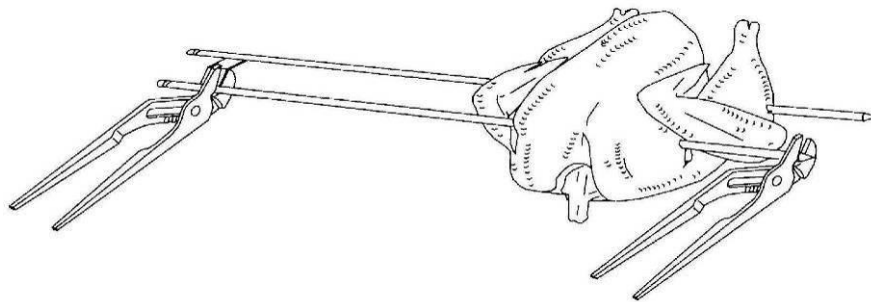

5.6.3 Rack Loading

- Load Rack as shown below.

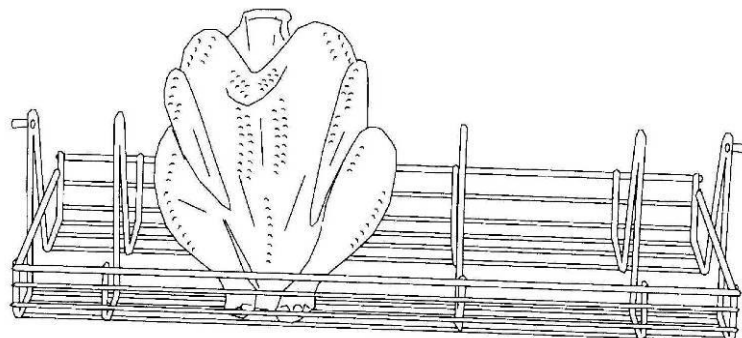

6 Maintenance

Following we will show you some advices concerning maintenance, care, trouble shooting and service for your Rotisserie „Top Line“.

6.1 Cleaning and care

6.1.1 Safety advices

- Before you start to clean and care switch off the appliance and disconnect it from the mains.
- Do not use inflammable detergents, sharp-edged or metallic things for cleaning the unit! Never use high-pressure-, water pressure- or steam jet- cleaning machines!
- Wear acidproof gloves while cleaning the parts to prevent skin irritations.



6.1.2 General Recommendations

- The unit has to be cleaned daily.
- Only use cleaning detergents that are appropriate for food (neutral or alkaline detergents), even if there are plain and persistent residues.
- After cleaning with special cleaners you have to wash all parts with clear water and dry them afterwards so that there are no residues of the cleaning detergent on these parts.
- It is absolutely necessary to watch out for some fundamental things to keep this longliving high-grade-steel-machine working:
 - always keep the high-grade-steel surface clean.
 - watch out that there is always enough fresh air on the surface
 - never contact the surface with rusty material
- Never use bleaching or chlorine cleaners.
- Take brushes with plastic or natural bristles for cleaning.



6.1.3 Detergents

To make the cleaning fast and easy we have integrated some cleaners in our program:

- Grill- and oven cleaner:
To dispose persistend, dried-up dirt on metal surfaces.
- Intensiv cleaner:
Detergent for metal- and plastic-surfaces.
- Glass cleaner:
Removes fat from glass-surfaces.
- Stainless steel cleaner
Spray the cleaner from a distance of app. 25 cm onto the surface and wipe it off with a dry cleaning rag. If you want to clean only small parts you have to spray it directly on the cleaning rag and wipe it off this way. With this method it is possible to clean the Rotisserie easily and without stripes.



6.1.4 Special cleaning hints

Please find below some special cleaning tips for this specific unit:

- Lamps:
To be cleaned only with soft paper or cloth and alcohol.
- Glass:
Remove dust and dirt from the glass surface with soft cloth to avoid scratches.
- Drawers:
Easily removable without tools for separate cleaning.



6.2 Trouble shooting

If your Rotisserie „Top Line“ does not work satisfactorily we would like to give a first help with the following check list. Only after checking these points you should contact:

a) your responsible service partner

or

b) directly the company: UBERT GASTROTECHNIK GMBH
Werk II Gewerbegebiet Nord
Vennekenweg 17
46348 Raesfeld
Tel.:02865 / 602-226
Service-Tel.:0172 / 2 82 86 31
Fax:02865 / 602-102 (or -103)

Only these two companies are allowed to carry out service work and replacement of defect parts. If you do not observe this note or in case of manipulation of a third party any claims for guarantee will become invalid!



Check list of your Rotisserie „Top Line“:

Failure		Possible cause	Remedy
1.	Rotisserie does not operate	Electrical supply is interrupted Fuse defect	Check the fuses! Unplugged? Call your local electrician!
2.	Fan motor does not work	mechanic hindrances Fan motor defect	Switch off the unit, remove the cover with ventilation grid, check the ventilation on mechanic hindrances (e.g. hardened fat residues – remove these carefully)! Call your service company. Do not start the unit!
3.	Quartz lamp is off	is not switched on. Lamp is defect.	Check the position of switch on/off knob. Replacement of the quartz lamp by a local electrician.
4.	Noisy motor	Motor or gear is defect.	Call the service company!
5.	Spit disks do not rotate.	Motor protection device has set. Doors are not closed (RT307 only)	Push the motor protection control one time, if it sets again call the service! Close the doors!
6.	Rotisserie does not reach the required temperature.	Electrical supply is not o.k. Heating elements are defect. Fan defect. Thermostat defect.	Check the fuse box! Call the service! See point 2 or call the service! Call the service!
7.	Difference between programmed and real time periods	Programming clock is defect.	Call the service!

6.3 Wiring Diagrams

RT 403 S

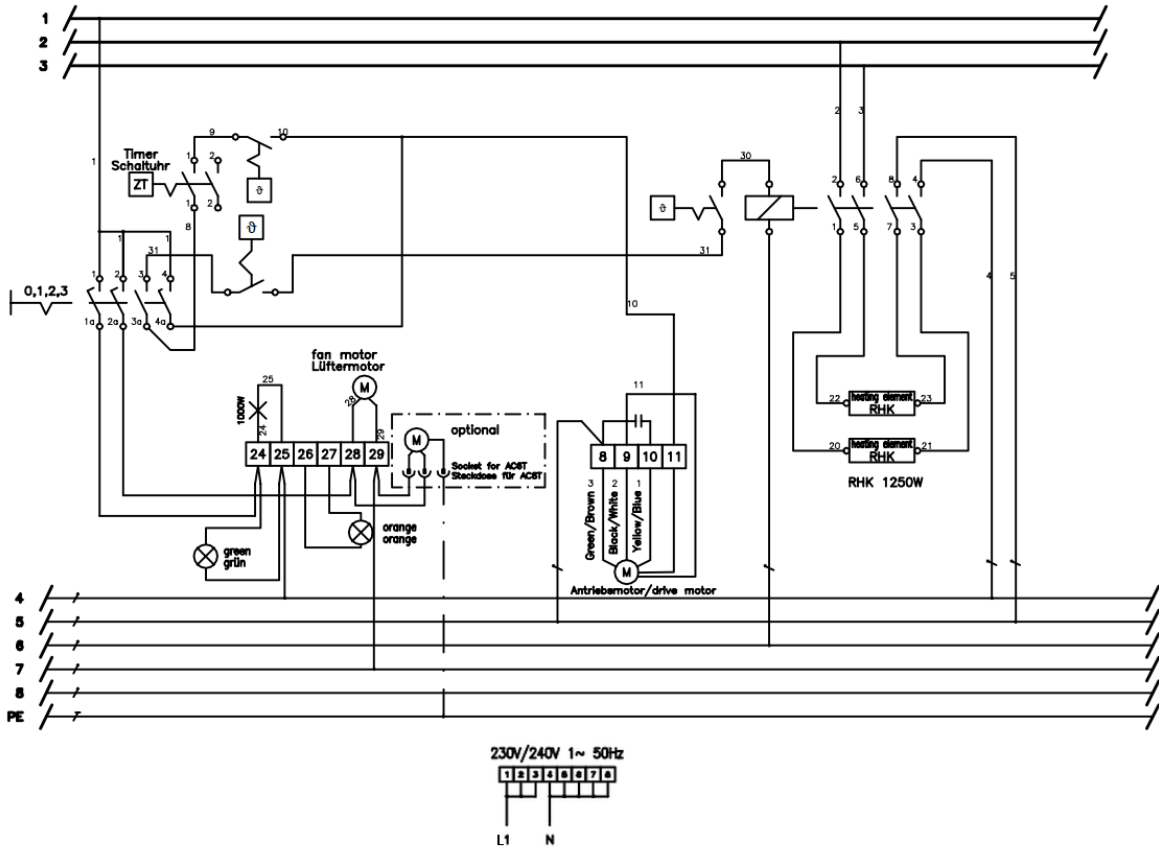

RT 403 S CC

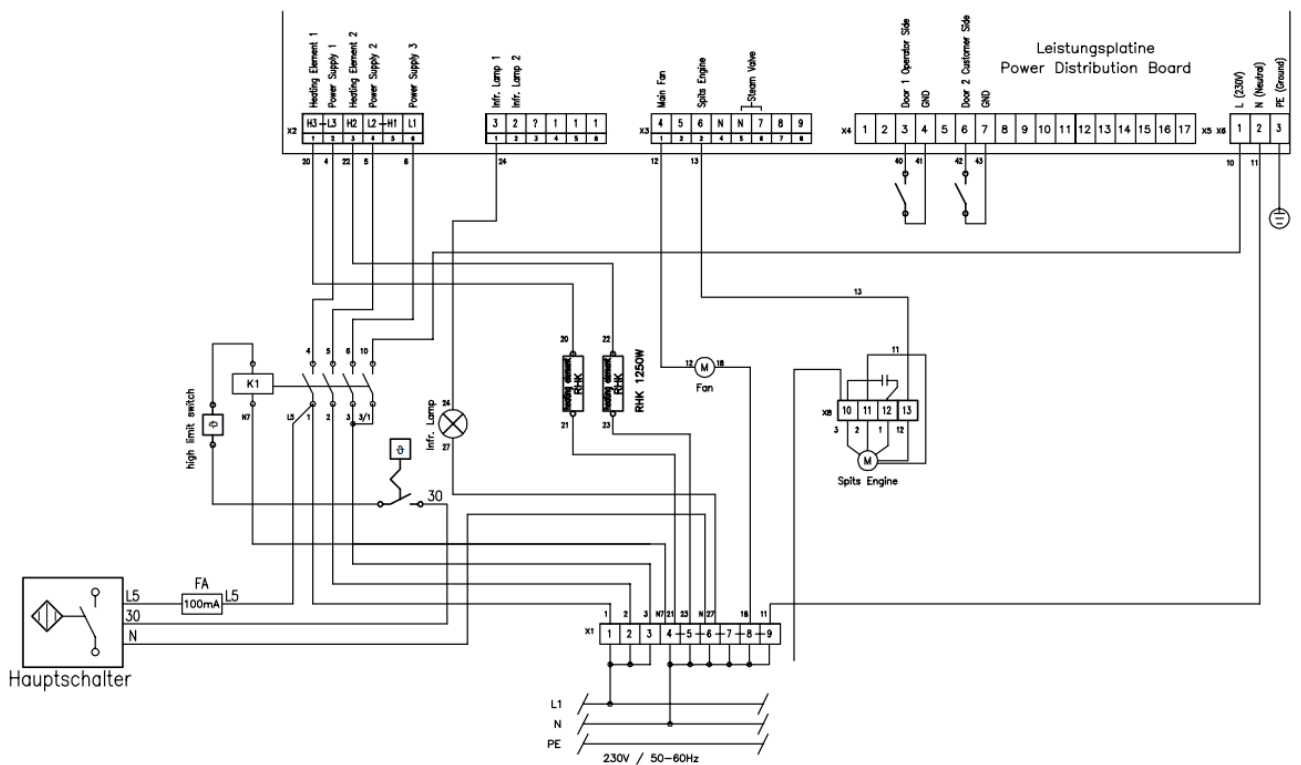

RT403 - RT406

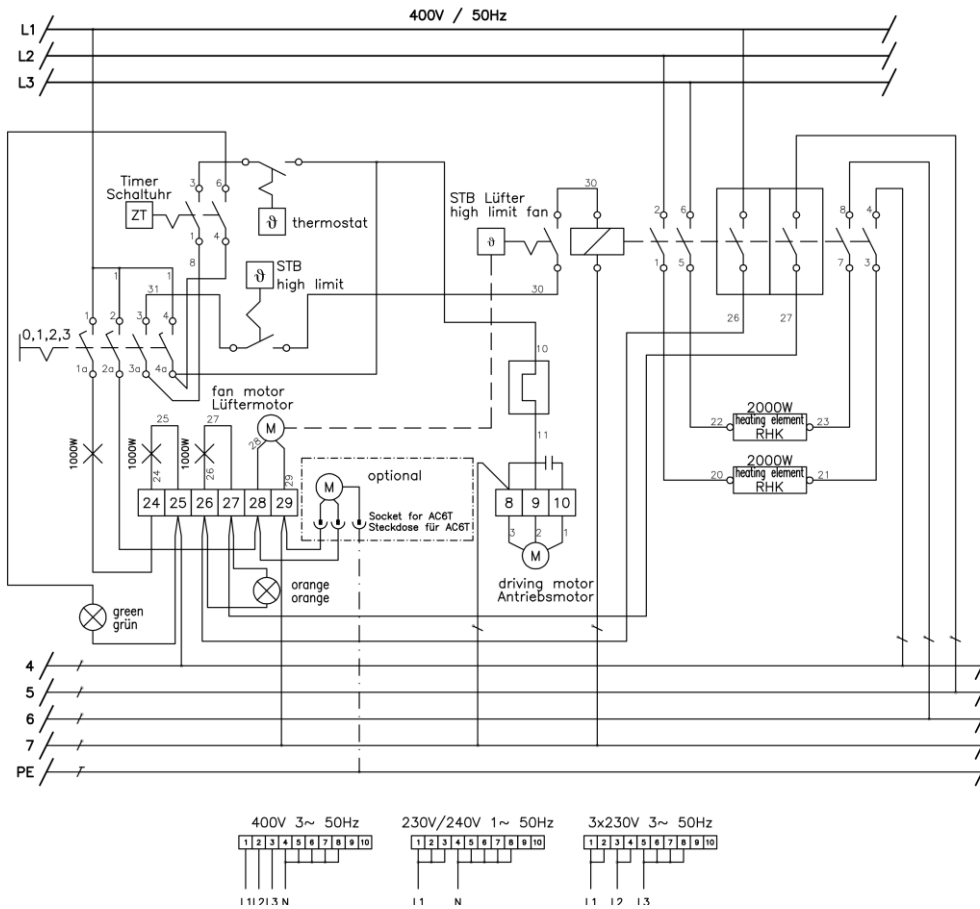

RT 403 CC - RT 406 CC

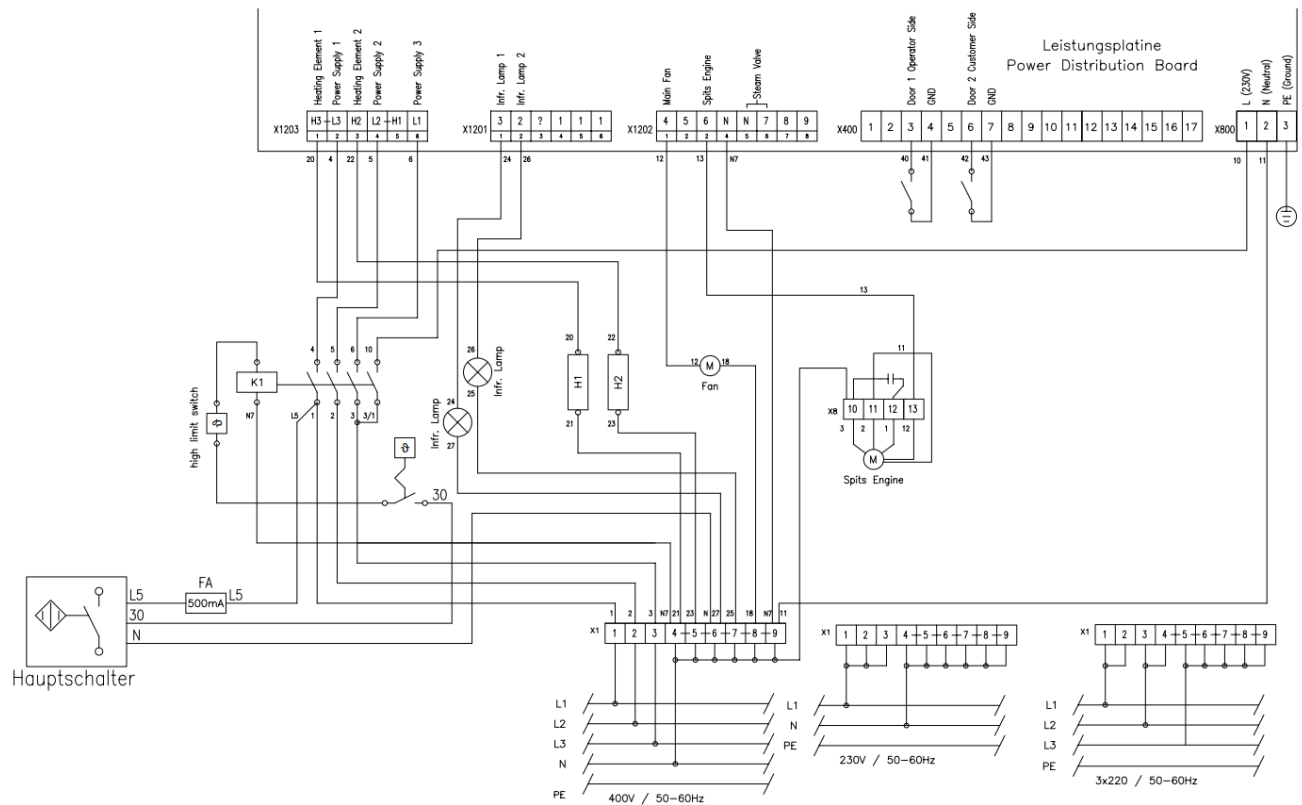

RT408

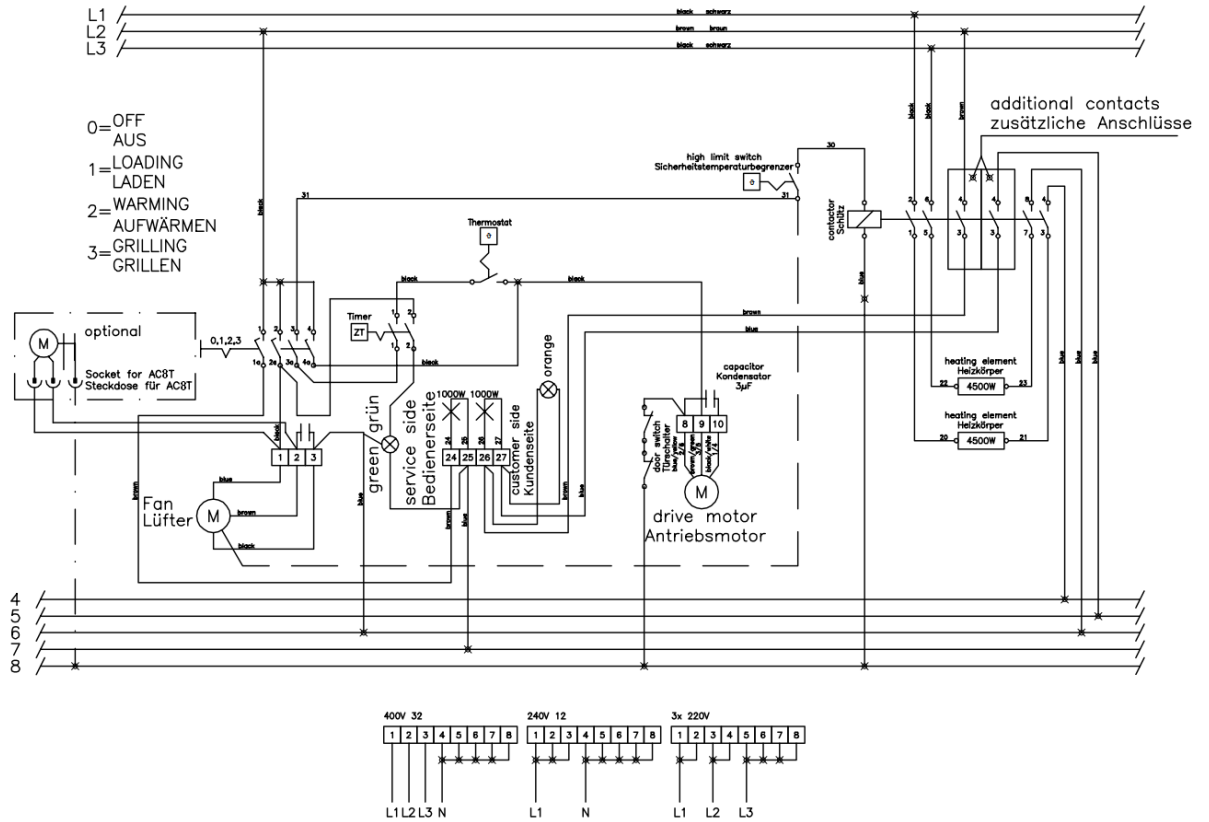

RT408 CC

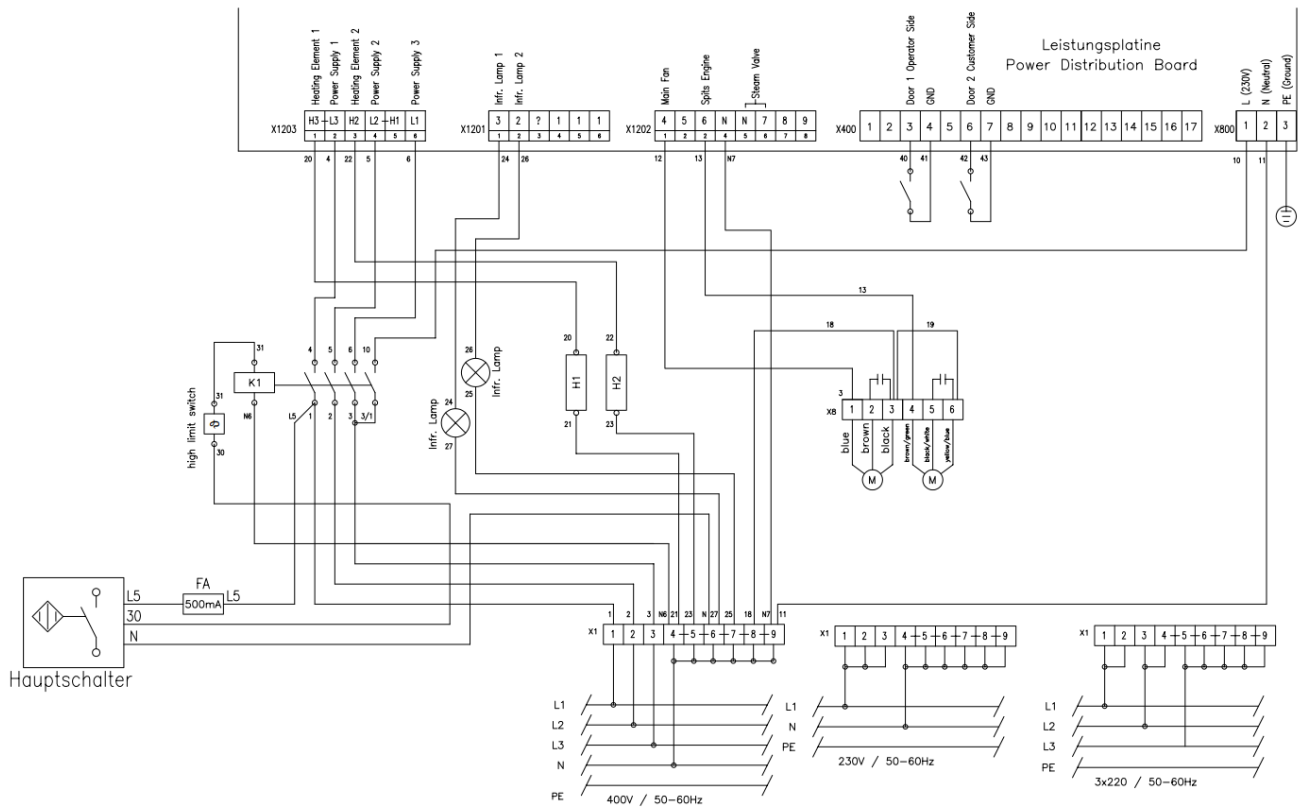

RT408 CC:

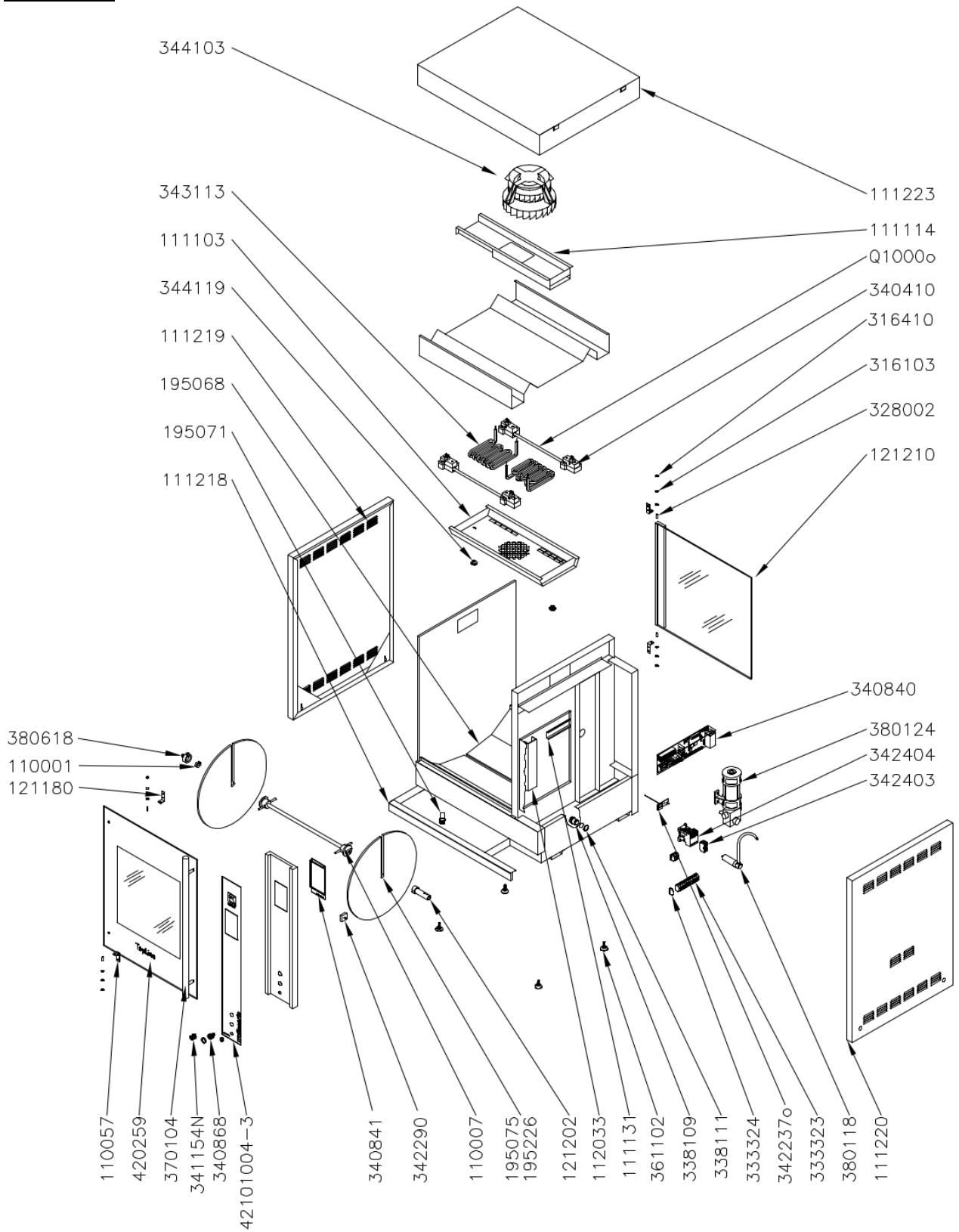

RT408 (manual controlled):

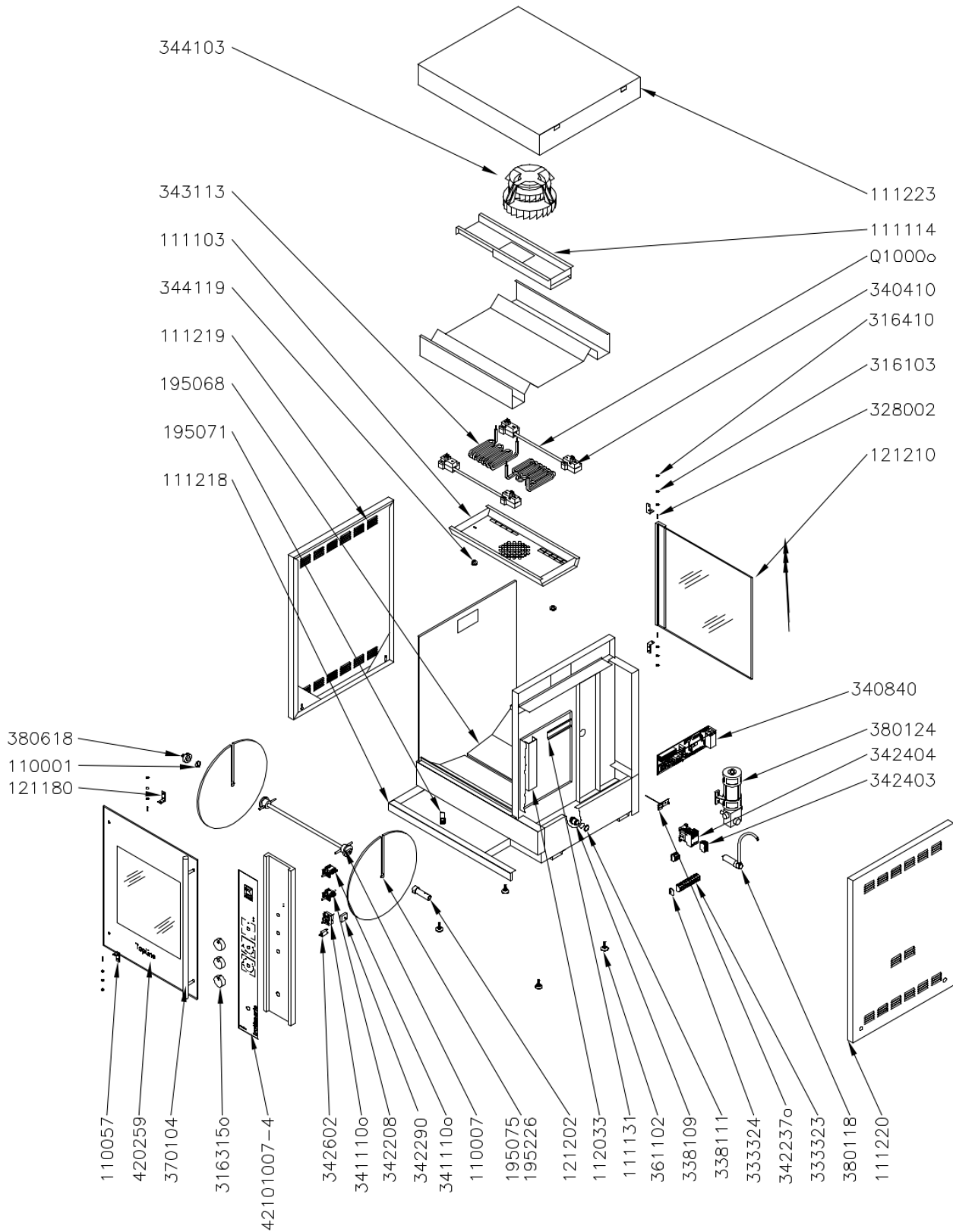

6.4.2 Spare Parts List

RT 403 S / RT403 S CC

Description	Part No.	Amount	VT
Operator panel RT403SCC (metal frame & glass)	150627	1	X
Operator panel RT403S (metal frame & glass)	150626	1	
shaft support assy	110001	1	
disk set RT 303	110003	1	
shaft assy	110007	1	
grease drawer assy	110018	1	
hinge front/top \ rear/bottom	110057	2	
fan cover assy	110271	1	
track for terminal blocks	111131	1	
door operator side assy	112011	1	
door customer side assy	112012	1	
side cover left assy	112046	1	
cable channel	112033	1	
fan box assy	120620	1	
hinge front/bottom \ rear/top	121180	2	
side cover right assy	112047	1	
knurled nut for fan wheel	121185	1	
shaft drive assy	121202	1	
top cover assy	121206	1	
grease guide plate assy	195070	2	
drain screw assy	195071	1	
washer	316103	8	
tab-washer	316410	2	
set srew M5x20	328002	2	
terminal block	333323	10	
end cap for terminal block	333324	1	
strain relief	338109	1	
lamp socket	340410	4	
rotary switch 4- positions	341110	1	
rotary switch automatic / manual	341116	1	
thermostat 230°C	342208	1	
high limit switch	342290	1	
temperature probe	342255	1	
Control Board UUS04	340841	1	
Power Board UUS04	340840	1	
aux. contact	342403	2	
contactor	342404	1	
overcurrent release cap	342601	1	
overcurrent release	342602	1	
main heating element 230V	343140	2	
fan wheel ø150	344110	1	
blower motor	344146	1	
knurled nut for fan cover assy	344119	2	
knurled nut, closed top M6	344159	1	
display UBERT	360161	1	
legs	361101	4	
knob	361311	3	
door handle	370115	1	
capacitor 3µF	380118	1	
gear motor	380103	1	
sliding sleeve for shaft support	380618	1	

RT 403 – RT406 / RT403 CC - RT406 CC

Description	Part No.	Amount	VT
Operator panel RT403-406CC (metal frame & glass)	150627	1	X
Operator panel RT412CC TOP (metal frame & glass)	150628	1	X
Operator panel RT412CC BOTTOM (metal frame & glass)	150629	1	X
Operator panel RT403-406 (metal frame & glass)	150626	1	
shaft support assy	110001	1	
disk set RT 303	110003	1	
disk set RT 304	110004	1	
disk set RT 305	121196	1	
shaft assy	110007	1	
grease drawer assy	110018	1	
hinge front/top \ rear/bottom	110057	2	
fan cover assy	110271	1	
track for terminal blocks	111131	1	
door operator side assy	112011	1	
door customer side assy	112012	1	
side cover left assy	112046	1	
cable channel	112033	1	
fan box assy	120620	1	
hinge front/bottom \ rear/top	121180	2	
side cover right assy	112047	1	
knurled nut for fan wheel	121185	1	
shaft drive assy	121202	1	
top cover assy	121206	1	
grease guide plate assy	195070	2	
drain screw assy	195071	1	
washer	316103	8	
tab-washer	316410	2	
set screw M5x20	328002	2	
terminal block	333323	10	
end cap for terminal block	333324	1	
strain relief	338109	1	
lamp socket	340410	4	
rotary switch 4- positions	341110	1	
rotary switch automatic / manual	341116	1	
thermostat 230°C	342208	1	
high limit switch	342290	1	
temperature probe	342255	1	
Control Board UUS04	340841	1	
Power Board UUS04	340840	1	
aux. contact	342403	2	
contactor	342404	1	
overcurrent release cap	342601	1	
overcurrent release	342602	1	
main heating element 230V	343140	2	
fan wheel ø150	344110	1	
blower motor	344146	1	
knurled nut for fan cover assy	344119	2	
knurled nut, closed top M6	344159	1	
legs	361101	4	
knob	361311	3	
door handle	370115	1	
capacitor 3µF	380118	1	
gear motor	380103	1	
sliding sleeve for shaft support	380618	1	

RT408 / RT408 CC

Description	Part No.	Amount	VT
Operator panel RT408CC (metal frame & glass)	150346	1	X
Operator panel RT416CC TOP (metal frame & glass)	150347	1	X
Operator panel RT416CC BOTTOM (metal frame & glass)	150348	1	X
Operator panel RT408 (metal frame & glass)	150345	1	
shaft support assy	110001	1	
hinge front/top \ rear/bottom	110057	2	
grease drawer assy	110131	1	
door customer side assy	110134	1	
shaft assy	110275	1	
top cover assy	110288	1	
fan cover assy	111103	1	
air guiding shield in fan box	111105	2	
cable channel	111130	1	
track for terminal blocks	111131	2	
hinge front/bottom \ rear/top	121180	2	
side cover right assy	112055	1	
door operator side assy	121210	1	
shaft drive assy	121217	1	
side cover left assy	112054	1	
fan box cover	195048	1	
air channel left	195052	1	
grease guide plate assy	195068	2	
drain scrow assy	195071	1	
disk set	195075	1	
knurled screw	311909	1	
washer	316103	8	
tab-washer	316410	4	
set screw M5x20	328002	4	
terminal block 10mm ²	333305	8	
terminal block	333323	6	
end cap for terminal block	333324	2	
strain relief PG 21	338112	1	
lamp socket	340410	4	
rotary switch 4- positions	341110	1	
rotary switch automatic / manual	341116	1	
door switch assy	341150	2	
thermostat	342208	1	
high limit switch	342290	1	
temperature probe	342255	1	
Control Board UUS04	340841	1	
Power Board UUS04	340840	1	
aux. contact	342403	2	
contactor	342412	1	
main heating element 240V 4,5kW	343113	2	
fan assy	344103	1	
knurled nut for fan cover assy	344119	4	
display UBERT	360165	1	
legs	361102	4	
knob	361311	3	
door handle	370200	2	
gear motor 240V	380124	1	
capacitor 4 μ F	380129	1	
capacitor 240V 5 μ F	380130	1	
sliding sleeve for shaft support	380618	1	

6.4.3 Replacement of Quartz Heater Lamps



Warning: Remove all electrical power supplied to the unit by unplugging the power cord or electrical shock could result. If the unit is permanently wired, the circuit breaker must be used to disconnect power.

1. Loosen two screws on both ends to remove the upper half of the lamps socket.
2. Use a 7mm wrench or nut driver and remove nut from lamps.

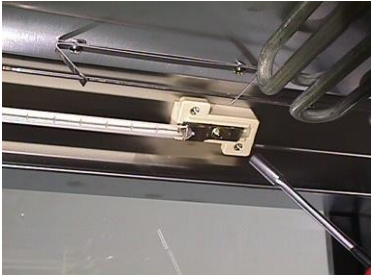

Caution: It is recommended not to touch heater with hands. Use gloves when replacing or damage to heater lamps could result.

3. Install new heater. Make sure to use the bras washer and securely tightening nut for heater wire. Hold the metal part of the lamp to avoid breaking it from the glass finally unwrap the paper around the lamp.



6.5 Declaration of Conformity

UBERT GASTROTECHNIK GMBH
Gewerbegebiet Ost + Nord
D-46348 Roesfeld
Telefon: +49 (0) 28 65 / 602-0
Fax: +49 (0) 28 65 / 602-102
Internet: www.ubert.com
e-mail: info@ubert.com

Übersetzung der Original-EU-Konformitätserklärung



CE EU-KONFORMITÄTSERKLÄRUNG EU-DECLARATION OF CONFORMITY EU-CERTIFICAT DE CONFORMITE

Hereby we declare that the unit noted below, on the basis of its concept, design and version, meets all basic health and safety requirements of the applicable EC-directive. This declaration is no longer effective in case this machine has been modified without our approval.

Product designation:	Rotisserie
Model:	RT403S / RT403 / RT404 / RT405 / RT406 / RT408 RT412 / RT416 RT403SCC / RT403CC / RT404CC / RT405CC / RT406CC / RT408CC RT412CC / RT416CC
EC-directives followed:	EC-directive for machines 2006/42/EC EC-directive for low voltage 2014/35/EU EC-directive for electromagnetic compatibility 2014/30/EU EC-directive for ecodesign requirements for energy-related products 2009/125/EC EC-directive for restriction of the use of certain hazardous substances 2011/65/EU
Harmonized European Standards:	EN 55014 Electromagnetic compatibility -- Requirements for household appliances EN 61000-6-2 Electromagnetic compatibility -- Generic immunity standard EN 60335-1 Safety of household and similar electrical appliances EN 60335-2 Safety of household and similar electrical appliances
Applied national standards and technical specifications:	BGR111 directions for safety and health protection regarding kitchen work

This declaration does not include any assurance of characteristics.

The safety references enclosed with the product documentation have to be followed.

By internal actions it is guaranteed, that all serial units meet the demands of the corresponding EC directive and the applied standards.

The signers are entitled to compose the technical documents.

Roesfeld, 01.01.22
UBERT GASTROTECHNIK GMBH
C. Stephan
Christoph Stephan
Vice President, R&D / Engineering

Roesfeld, 01.01.22
UBERT GASTROTECHNIK GMBH
M. Peters
Michael Peters
Service - Manager

Manufactured by: UBERT GASTROTECHNIK GMBH
Gewerbegebiet Ost + Nord
D-46348 Roesfeld