



F900

G9341F Single Pan Gas Fryer with Filtration

Key features

- High efficiency burner system
 - Quick heat up, reduced waiting time
- Oil capacity is just 18 litres
 - Efficient to heat and economical to fill up
- Automatic integrated 2-stage filtration
 - Increases oil longevity and quality
- Manual controls
 - Simple and ease to use
- Integrated fat melt cycle
 - Ability to use different cooking mediums
- IPX5 rated
 - Easy and problem-free cleaning
- Supplied with fish grid, lid and oil bucket
 - Everything you need to operate the fryer
- Stainless steel panels with Scotch Brite finish
 - Looks great, ideal for front-of-house kitchens
- Dynamic Link System compatible
 - Integrated linking system allows quick and easy installation to create a seamless, continuous cookline

Accessories

- Front hob rail
- Kick strip
- Rear blanking plate
- Side hob extension
- Factory fitted, adjustable castors



Similar Models

- G9341 single pan gas fryer
- E9341 single pan electric fryer
- E9341F single pan electric fryer with filtration

F900

G9341F

Single Pan Gas Fryer with Filtration

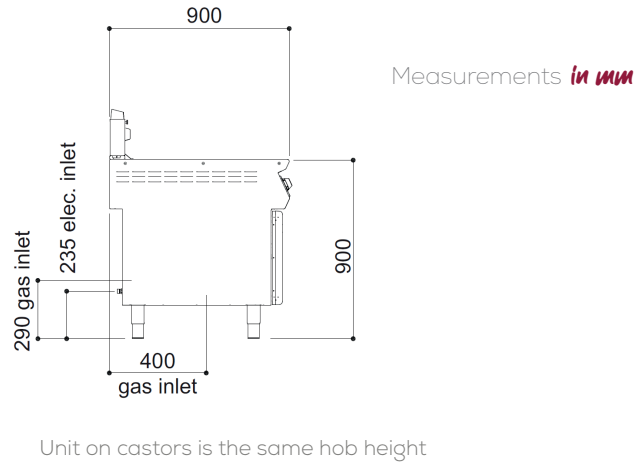
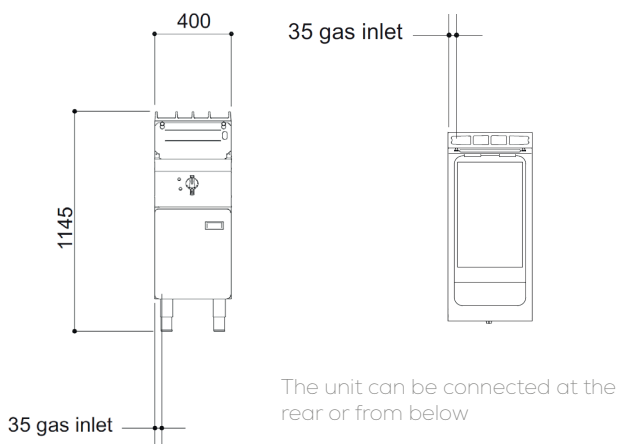

Specification details

| | Natural Gas | Propane Gas | Butane Gas |
|--|-------------------------|-------------------|------------|
| Total rating (kW - Nett) | 23 | 22 | 22 |
| Total rating (btu/hr - gross) | 86,348 | 82,594 | 82,594 |
| Inlet size | 3/4" BSP | 3/4" BSP | 3/4" BSP |
| Flow rate - natural (m ³ /hr) | 2.26 m ³ /hr | 1.60 kg/h | 1.57 kg/h |
| Inlet pressure (mbar) | 20 | 37 | 29 |
| Operating pressure (mbar) | 14 | 37 | 29 |
| Burner rating * (kW) | 23 | 22 | 22 |
| Burner rating * (btu/hr) | 86,348 | 82,594 | 82,594 |
| Electrical supply | 230V~ | | |
| Oil capacity (litres) | 18 | | |
| Chip Output (kg/hr) | 32 | | |
| Weight (kg) | 94 | | |
| Packed weight (kg) | 95 | | |
| Packed dimensions (w x d x h - mm) | 490 x 1000 x 1015 | | |
| GTIN number | G9341F on feet | G9341F on castors | |

Short Form specification

Unit to be Falcon F900 Series high performance gas single pan, twin basket fryer with in-built filtration. Unit to be supplied upon adjustable feet with a working oil capacity of 18 litres.

The pan will be of open well design with burner situated below - allowing easy cleaning of the pan. Unit to be supplied with two baskets with coated handles that can be positioned at pan rear for oil drain off and storage. Oil to be drained from pan via large 1" drain valve into oil bucket which is to be self-contained inside the unit base. The oil temperature will be thermostatically controlled via precise controls from 130-190°C. The unit will have safety thermostat fitted as standard to prevent unit from overheating.

The hob will be constructed from 2mm 304 grade stainless steel. Hobs will be laser cut with right-angled edges to allow joining of units with no gaps between hobs. Exterior panels are Scotch Brite finish stainless steel. Control knobs to be marked showing gas positions and to have a bezel behind each knob to prevent water ingress. Unit will be for use with natural, propane or butane gas and be supplied with conversion kit.

Installation note

Please consult local legislation with regard to installation of cooking equipment.



Falcon Foodservice Equipment, Wallace View, Hillfoots Road, Stirling FK9 5PY Scotland
 t: +44 (0) 1786 455 200 e: info@falconfoodservice.com www.falconfoodservice.com