

## Rack Type Dishwasher with Drier (Hot Feed)

CNE-A CDS

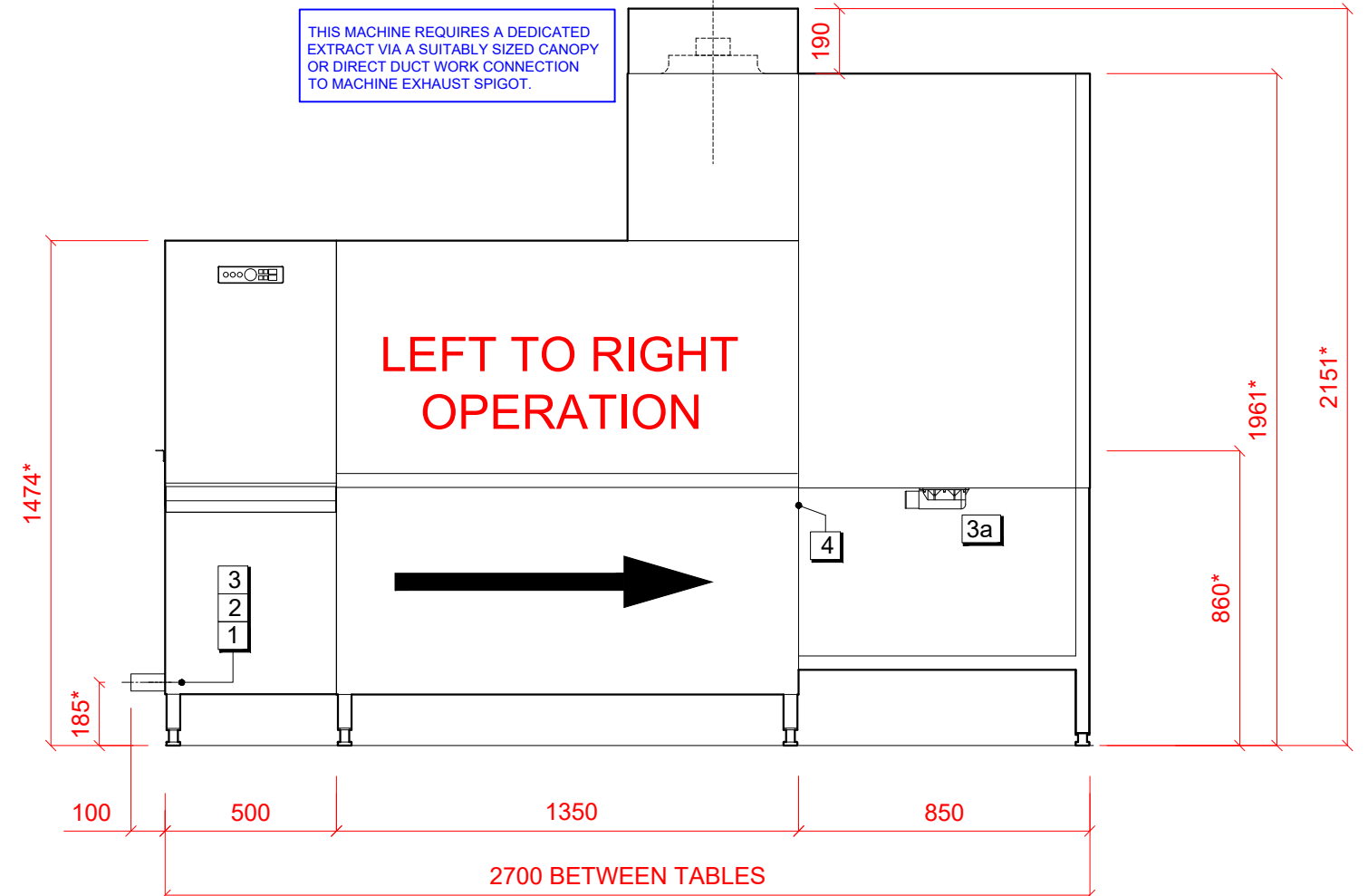
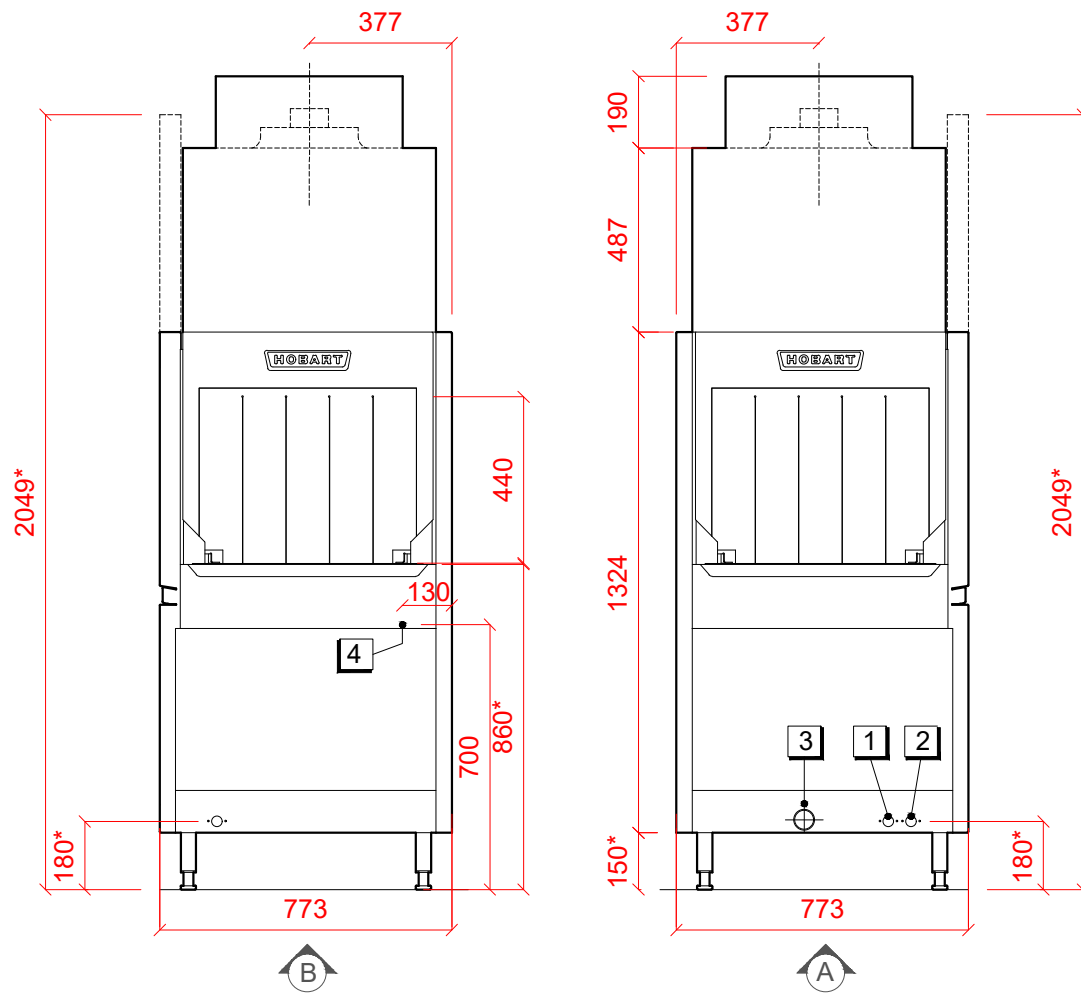
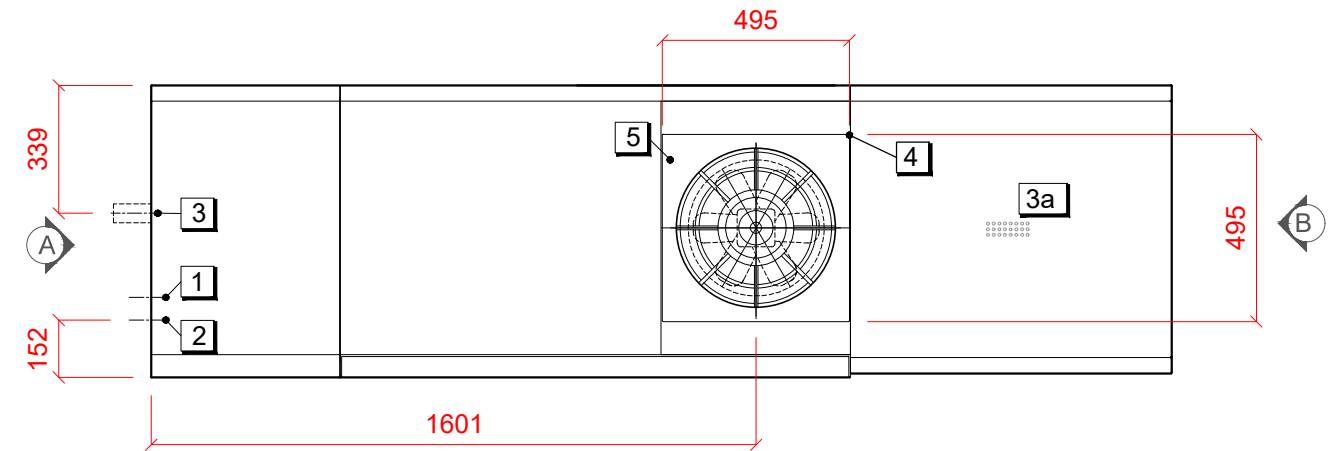

1	2	3	4	5	Notes
<b>Fresh water for rinse</b> 3/4" B.S.P. 50°C 1.5 BAR MIN TO 6.0 BAR MAX. MAX HARDNESS 8° CLARK. USAGE 150 LITRES PER HOUR.	<b>Water for tank fill</b> 3/4" B.S.P. 50°C 1.0 BAR MIN TO 6.0 BAR MAX. INITIAL TANK FILL 125 LITRES. MAX HARDNESS 8° CLARK <b>NOTE:</b> FILLING WITH WATER AT LESS THAN 50°C WILL INCREASE INITIAL HEAT UP AND RECOVERY TIMES.	<b>Main machine drain</b> MAIN MACHINE: GRAVITY DRAIN 50mm INSIDE DIAMETER PEAK FLOW RATE 55 LITRES/MINUTE <b>3a Drier Drain</b> 1.5" B.S.P.	<b>Electric Loading</b> CN-E-A (HOT FEED RINSE) with CDS DRIER 400/50/3 + N + E 27.8kW FUSE AT 50amps/PHASE	<b>Extract requirements</b> MACHINE FITTED WITH EXHAUST FAN DISCHARGING 280m <sup>3</sup> /hr AT 44°C-46°C AND 95% rf. THERE SHOULD BE A GENERAL PROVISION FOR ROOM VENTILATION DELIVERING A MINIMUM OF 30 AIR ROOM CHANGES PER HOUR AS PER DW172	CLASS 'AA' AIR GAP FITTED AS STANDARD. HEIGHTS MARKED * REPRESENT ±25mm. MINIMUM CLEARANCE FROM REAR WALL 44mm.